

Rajametsäntie 35 A, B, C Maunula

Talon rakentamivuosi 1962.

Hissihankkeen kokonaiskustannukset (2013): 585 999 €, taloyhtiön osuus avustuksien jälkeen 288 015 € (3 hissiä) eli 96 005 € / hissi.



A-portaikon uusi valoisa hissi.

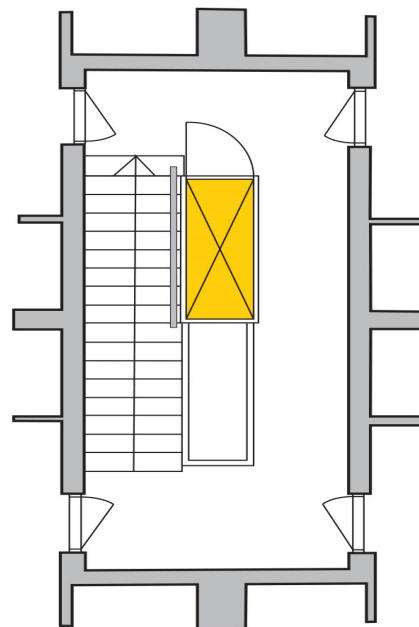

A-portaikon pohjapiirustus.



Portaikko säilyy valoisana.

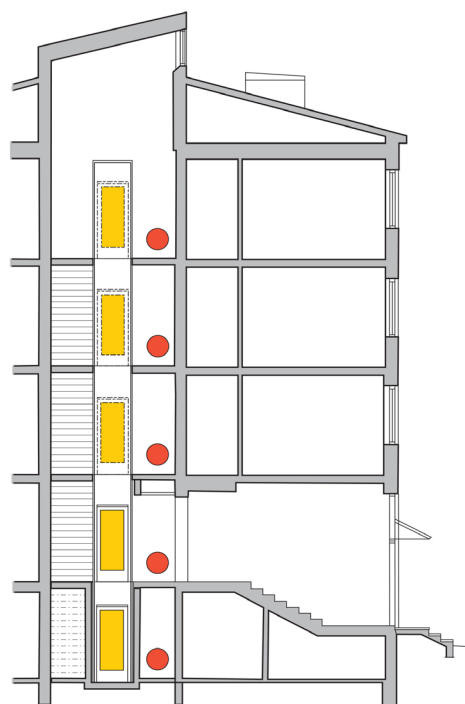

● Hissipysäkki
Portaikon leikkauspiirustus.

Arkkitehtitoimisto Mirja ja Pekka Koski-Lammi

Facebook: Hissit Stadin kerrostaloihin

www.hel.fi/hissiprojekti



Helsingin kaupunki
Kaupunginkanslia

Talous- ja suunnitteluosasto, hissi projekti
Hissiasiamies Simo Merilä puh (09) 310 36122
simo.merila@hel.fi





Sisääntuloaula.

Simo Merilä

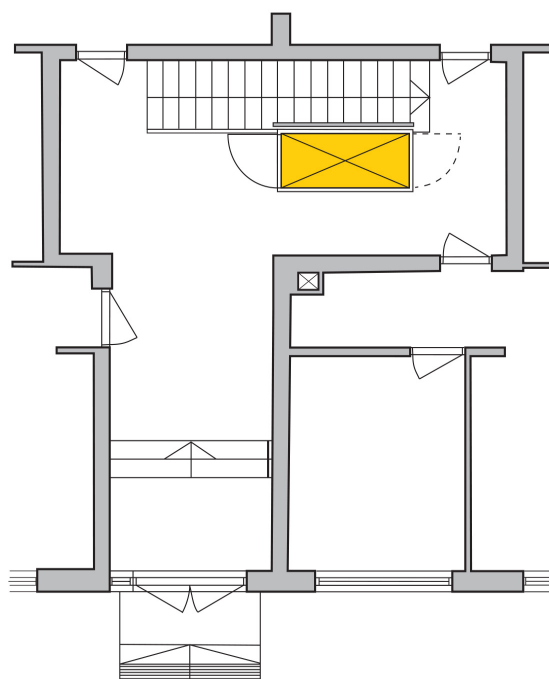

Sisääntulokerros.



Kellarikerros.

